

A Novel Method to Manage Direct Flux and Torque Control of Induction Motor Drive using PI and Fuzzy Logic Controllers



I Mohan Rao

PG Student

SSN Engineering College,
Ongole -523 002, Prakasam (Dist.), A.P.



Mr. B.Naga Raju, M.Tech

Professor & H.O.D,

SSN Engineering College,
Ongole -523 002, Prakasam (Dist.), A.P.

ABSTRACT

This paper presents a direct flux and torque control of three phase induction motor drive using PI and Fuzzy logic controller. The DTC is one of the most excellent direct control strategies of stator flux and torque ripple of IMD. The conventional method of DTC, it uses PI for speed regulator where speed reduced under transient and dynamic state. This drawback was reduced by the proposed system the speed is regulated by PI and torque is controlled by fuzzy logic controller. The control system is based on DTC operating principles. The DTC is achieved by reference of stator flux and is generates from instantaneous actual and reference stator fluxes and the reference of torque is from FLC.

Keywords: Conventional PI controller, Direct Torque Control, Fuzzy Logic Control, Induction Motor Drives, Space Vector Modulation.

1. Introduction

The history of electrical motors goes back as far as 1820, when Hans Christian Oersted discovered the magnetic effect of an electric current. One year later, Michael Faraday discovered the electromagnetic rotation and built the first primitive D.C. motor. Faraday went on to discover electromagnetic induction in 1831, but it was not until 1883 that Tesla invented the A.C asynchronous

motor [2]. Currently, the main types of electric motors are still the same, DC, AC asynchronous and Synchronous, all based on Oersted. Faraday and Tesla's theories developed and discovered more than a hundred years ago. Before the introduction of micro-controllers and high switching frequency semiconductor devices, variable speed actuators were dominated by DC motors.

Today, using modern high switching frequency power converters controlled by microcontrollers, the frequency, phase and magnitude of the input to an AC motor can be changed and hence the motor's speed and torque can be controlled. AC motors combined with their drives have replaced DC motors in industrial applications due to their lower cost, better reliability, lower weight, and reduced maintenance requirement. Squirrel cage Induction motors are more widely used than all the rest of the electric motors put together as they have all the advantages of AC motors and they are easy to build [2]. The main advantage is that induction motors do not require an electrical connection between stationary and rotating parts of the motor.

Therefore, they do not need any mechanical commutator (brushes), leading to the fact that they are maintenance free motors. Induction motors also have low weight and inertia, high efficiency and a high overload capability. Therefore, they are cheaper and more robust, and less

proves to any failure at high speeds. Furthermore, the motor can work in explosive environments because no sparks are produced. Taking into account all the advantages outlined above, induction motors must be considered the perfect electrical to mechanical energy converter.

However, mechanical energy is more than often required at variable speeds, where the speed control system is not a trivial matter. The only effective way of producing an infinitely variable induction motor speed drive is to supply the induction motor with three phase voltages of variable frequency and variable amplitude. A variable frequency is required because the rotor speed depends on the speed of the rotating magnetic field provided by the stator. A variable voltage is required because the motor impedance reduces at low frequencies and consequently the current has to be limited by means of reducing the supply voltages [3] [4] [5]. Before the days of power electronics, a limited speed control of induction motor was achieved by switching the three- stator windings from delta connection to star connection, allowing the voltage at the motor windings to be reduced. Induction motors are also available with more than three stator windings to allow a change of the number of pole pairs.

However, a motor with several windings is more expensive because more than three connections to the motor are needed and only certain discrete speeds are available. Another alternative method of speed control can be realized by means of a wound rotor induction motor, where the rotor winding ends are brought out to slip rings. However, this method obviously removes most of the advantages of induction motors and it also introduces additional losses. By connecting resistors or reactance in series with the stator windings of the induction motors, poor performance is achieved. With the enormous advances made in semiconductor technology during the last 20 years, the required conditions for developing a proper induction motor drive are present. These conditions can be divided mainly in two groups:

- The decreasing cost and improved performance in power electronic switching devices.[5]
- The possibility of implementing complex algorithms in the new microprocessors.

However, one precondition had to be made, which was the development of suitable methods to control the speed of induction motors, because in contrast to its mechanical simplicity their complexity regarding their mathematical structure (multivariable and non-linear) is not a trivial matter. Historically, several general controllers have been developed:

A. Scalar controllers

Despite the fact that "Voltage-Frequency" (V/f) is the simplest controller, it is the most widespread, being in the majority of the industrial applications. It is known as a scalar control and acts by imposing a constant relation between voltage and frequency. The structure is very simple and it is normally used without speed feedback. However, this controller doesn't achieve a good accuracy in both speed and torque responses, mainly due to the fact that the stator flux and the torque are not directly controlled. Even though, as long as the parameters are identified, the accuracy in the speed can be 2% (except in a very low speed), and the dynamic response can be approximately around 50ms [6].

B. Vector Controllers

In these types of controllers, there are control loops for controlling both the torque and the flux. The most widespread controllers of this type are the ones that use vector transform such as either Park or Ku [3]. Its accuracy can reach values such as 0.5% regarding the speed and 2% regarding the torque, even when at stand still. The main disadvantages are the huge computational capability required and the compulsory good identification of the motor parameters [7] [8] [9].

C. Field Acceleration method

This method is based on maintaining the amplitude and the phase of the stator current constant, while avoiding

electromagnetic transients. Therefore, the equations used can be simplified saving the vector transformation, which occurs in vector controllers. This technique has achieved some computational reduction, thus overcoming the main problem with vector controllers and allowing this method to become an important alternative to vector controllers [10] [11] [12].

A single-phase or three-phase AC power supply and an AC/DC converter provide a DC input to an inverter. A micro-controller decides the switching states for the inverter to control the motor's torque or speed. A sensing unit feeds back terminal values such as motor speed, voltage and current to the micro-controller as needed for the closed-loop control of the motor. Controllers used in AC motor drives are generally referred to as vector or field-oriented controllers mentioned above. The field-oriented control methods are complex and sensitive to inaccuracy in the motor's parameter values. Therefore, in this field, a considerable research effort is devoted. The aim being to find even simpler methods of speed control for induction machines. One method, which is popular at the moment, is:

Direct Torque Control (DTC): This method has emerged over the last decade to become one possible alternative to the well-known Vector Control of Induction Machines. Its main characteristic is the good performance, obtaining results as good as the classical vector control but with several advantages based on its simpler structure and control diagram.

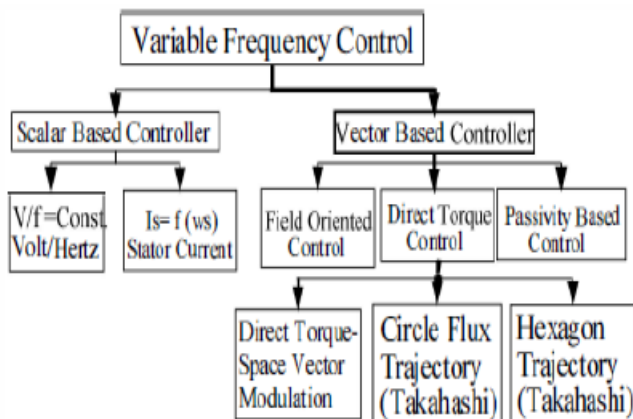

2. Features Of Direct Torque Control

DTC main features are as follows:

- Direct control of flux and torque.
- Indirect control of stator currents and voltages.
- Approximately sinusoidal stator fluxes and stator currents.
- High dynamic performance even at stand still.

The main advantages of DTC are:

- Absence of co-ordinate transforms.
- Absence of voltage modulator block, as well as other controllers such as PID for motor flux and torque.
- Minimal torque response time, even better than the vector controllers.

However, some disadvantages are also present such as:

- Possible problems during starting.
- Requirement of torque and flux estimators, implying the consequent parameters identification.
- Inherent torque and stator flux ripple.

The electric drives are used for motion control. Now a days around 70% of electric power consumed by electric drives. This electric drives are mainly AC and DC drives. During last four decades AC drives are become more and more popular, especially induction motor Drives (IMD), because of high efficiency, high performance, and rugged structure ease of maintenance so widely used in industrial application, such as paper miles, robotics, steel miles, servos, transportation system, elevators, machines tools etc. The IMD control methods can be divided into two methods such as, scalar and vector control. The general classification of the variable frequency controls is presented. The scalar control is operating in steady state and controls the angular speed of current, voltage, and flux linkage in the space vectors. Thus, the scalar control does not operating in the space vector position during transient state.

The vector control, which is based on relations valid for dynamic states, not only angular speed and magnitude but also instantaneous position of current, voltage, and flux linkage space vector are controlled. In the vector control, the most popular method for induction motor drives, known as Field Oriented Control (FOC) presented by F.Blaschke (Direct FOC) and Hasse (Indirect FOC) in early 1970's, gives high performance, and high efficiency for industrial applications [1]. In the FOC, the motor equations are transformed into a coordinate system that rotates in synchronism with the rotor flux vector control [2]. This drawback was eliminated using the new strategies for torque and flux ripple control of IMD using DTC was proposed by Isao Takahashi and Toshihiko Noguchi, in the mid 1980's [3]. The main feature of DTC is simple structure and good dynamic behavior and high performance and efficiency [4]. The new control strategies proposed to replace motor linearization and decoupling via coordinate transformation, by torque and flux hysteresis controllers [5]-[7]. This method referred as conventional DTC [8].

In the conventional DTC using PI based SR, there are more disadvantages, such as, variable switching frequency, high torque and flux ripple, problem during starting and low speed operating conditions, and flux and current distortion caused by stator flux vector changing with the sector position, in those most important is the speed of IMD is changing under transient state to steady state operating condition [9]. This drawback was eliminated using fuzzy logic control speed regulator instead of conventional PI speed regulator [10].

3. Mathematical Model Of Induction Motor Drive

The mathematical model of induction motor drives when the motor is operating in both the steady state and transient states. The standard IMD equivalent model can be used to calculate motor variables such as developed torque, flux, stator voltage, stator current, and rotor current, etc. The induction motor can be modeled with

stator current and flux in reference (dS_qS) as state variable expressed as follows.

$$x'(t) = Ax(t) + Bu(t)$$

$$Y(t) = Cx(t)$$

Where A is System matrix, B is the control and C is the observation, and X(t) is the state variable, u(t) is input vector and y is output vector. An improved method of speed estimation that operates on the principle of a speed adaptive flux observer. An observer is basically an estimator that uses a plant model and a feedback loop with measured plant variables.

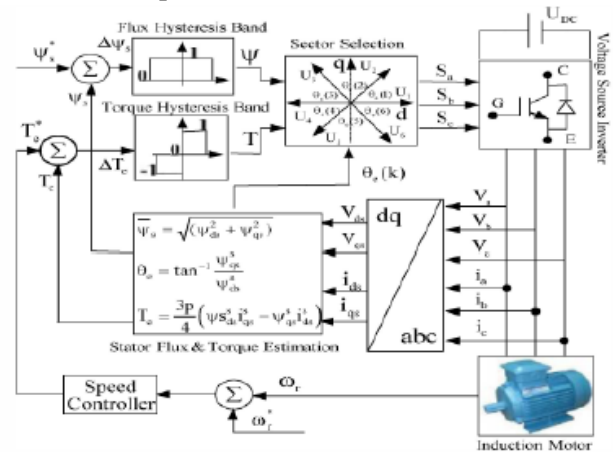

4. Direct Torque And Flux Control With 2- Level Inverter

The schematic diagram of conventional direct torque control of induction motor drive. A torque and flux hysteresis comparators (T,ψ), the reference values of torque and flux (T*e , ψ*s), voltage vector sector selection, torque and flux estimators (ψ s, Te), induction motor, real speed value ((Or), stator flux angle δe(k), and voltage source inverter (VSI) [10].

A. Voltage Source Inverter (VSI)

The 2-level and 3-phase VSI has eight possible voltage space vectors, in this six active voltage vectors (U1-U6) and two zero voltage vectors (U7,U8), according to the combination of the switching modes are Sa, Sb, and Sc. When the upper part of switches is ON, then the switching value is '1' and when the lower switch is ON,

then the switching value is '0'. The stator voltage vector is equation (3).

$$\vec{U}_{s,k} = (2/3) U_{dc} [s_a + a s_b + a^2 s_c]$$

Where UDC is the dc link voltage of inverter, $a = ej2\pi/3$. The stator phase voltages are estimated using the following equations:

$$\begin{bmatrix} U_a \\ U_b \\ U_c \end{bmatrix} = \frac{U_{dc}}{3} \begin{bmatrix} 2 & -1 & -1 \\ -1 & 2 & -1 \\ -1 & -1 & 2 \end{bmatrix} \begin{bmatrix} S_a \\ S_b \\ S_c \end{bmatrix}$$

The behavior of induction motor drive using DTC can be described in term of space vector model is written in the stator stationary reference frame.

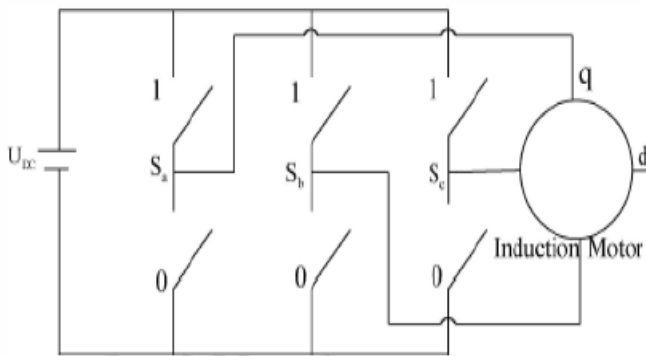

B. Direct Flux Control

The implementation of the DTC scheme requires torque and flux linkage computation and generation of vector switching states through a feedback control of the flux and torque directly without inner current loops. The stator flux in the stationary reference frame (dS qS) can be estimated as [10]

C. Direct Torque Control

The electromagnetic torque error is produced through torque hysteresis controller to produce error state signal T_e . The torque hysteresis loop control has three levels of digital output, which have the following relations. Finally the stator output voltage is applied based on the selection of the switching states from voltage vector selector table. The switching states are selected based on whether the stator flux and torque need to be decreased or increased and also on the stator flux angle position.

5. Statement Of The Problem

A simplified variation of field orientation known as direct torque control (DTC) was developed by Takahashi [1] and Depenbrock [13]. DTC of an induction motor. In direct torque controlled induction motor drives, it is possible to control directly the stator flux linkage and the electromagnetic torque by the selection of an optimum inverter switching state. The selection of the switching state is made to restrict the flux and the torque errors within their respective hysteresis bands and to obtain the fastest torque response and highest efficiency at every instant.

DTC is simpler than field-oriented control and less dependent on the motor model, since the stator resistance value is the only machine parameter used to estimate the stator flux. One of the disadvantages of DTC is the high torque ripple. Under constant load in steady state, an active switching state causes the torque to continue to increase past its reference value until the end of the switching period. Then a zero voltage vector is applied for the next switching period causing the torque to continue to decrease below its reference value until the end of the switching period. That results in high torque ripple. A possible solution to reduce the torque ripple is to use a high switching frequency; however, that requires expensive processors and switching devices. A less expensive solution is to use duty ratio control.

In DTC with duty ratio control, the selected voltage vector is applied for a part of the switching period rather than the complete switching period as in conventional DTC. By applying a nonzero voltage vector for only a portion of the switching period, and the zero voltage vector for the remainder of the period, the effective switching frequency is doubled. Therefore, over any single switching period, the torque variations above and below the average value are smaller. Further, because the duty ratio is controlled, the average stator voltage is adjusted directly. There is no need to make coarse corrections by the use of multiple switching periods with

a nonzero voltage vector or a whole switching period with a zero voltage vector.

The average phase voltage is adjusted more smoothly, and the overall torque ripple is reduced. The use of a duty ratio fuzzy controller is proposed in [3][14]. The theme of this thesis is to verify by simulation that a DTC with a duty ratio fuzzy controller reduces the torque ripple compared to conventional DTC. From the torque waveform obtained from simulation of conventional DTC, it is cleared that the torque ripple is 0.6 Nm (approximately 1.8-1.2 Nm maximum and minimum values respectively) with the conventional DTC. This high magnitude of torque ripple is the main drawback of conventional DTC. The other drawbacks also summarized as follows:

- Large and small errors in flux and torque are not distinguished. In other words, the same vectors are used during start up and step changes and during steady state.
- Sluggish response (slow response) in both start up and changes in either flux or torque.

In order to overcome the mentioned drawbacks, there are different solutions, like Non artificial intelligence methods, mainly "sophisticated tables" and fuzzy logic based systems.

In the next sections of my thesis work deal with DTC with the duty ratio fuzzy control to minimize torque ripple and realized the best DTC improvement.

6. Fuzzy Logic Controller

The fuzzy logic control is one of the controller in the artificial intelligence techniques the schematic model of the DTC of IMD and FLC based SR. In paper the Mamdani type FLC is using. In the DTC of IMD using conventional PI controller based SR are requires the precise mathematical model of the system and appropriate gain values of PI controller to achieve high performance drive. Therefore, unexpected change in load conditions would produce overshoot, oscillation of

the IMD speed, long settling time, high torque ripple, and high stator flux ripples.

To overcome this problem, a fuzzy control rule look-up table is designed from the performance of speed response of the DTC of IMD. According to the speed error and change in speed error, the proportional gain values are adjusted on-line [8]. A FLC converts a linguistic control strategy into an automatic control strategy, and fuzzy rules are constructed by expert knowledge or experience database. Firstly, the input speed $L1cor(k)$ and the change in error speed $L1co;$ (k) have been placed of the speed to be the input variables of the FLC.

Then the output variable of the FLC is presented by the control reference torque . To convert these numerical variables into linguistic variables, the following five fuzzy levels or sets are chosen as: NL (negative large), NS (negative small), ZE (zero), PS (positive small), and PL (positive large). The fuzzy controller is characterized as follows:

- 1) Five fuzzy sets for each input and output variables,
- 2) Fuzzification using continuous universe of discourse,
- 3) Implication using Mamdani's 'min' operator,
- 4) De-fuzzification using the 'centroid' method.

Fuzzification: the control process of converting a numerical variable (real number) convert to a linguistic variable (fuzzy number) is called fuzzification. De-fuzzification: the rules of the FLC generate required output variable in a linguistic variable (Fuzzy Number), according to the real world requirements, linguistic variables have to be transformed to crisp output (Real number). Database: the database stores the definition of the membership Function required by fuzzifier and defuzzifier [12].

A. Fuzzy Variables

In the crisp variables of the speed error and change in speed error are converted into fuzzy variables $L1cor(k)$ and $L1co;$ (k) that can be identified by the level of

membership functions in the fuzzy set. The fuzzy sets are defined with the triangular membership functions.

B. Fuzzy Control Rules

In the fuzzy membership function there are two input variables and each input variable have five linguistic values, so $5 \times 5 = 25$ fuzzy control rules are in the fuzzy reasoning.

Why fuzzy logic controller (FLC)

- Fuzzy logic controller is used to design nonlinear systems in control applications.

The design of conventional control system essential is normally based on the mathematical model of plant .if an accurate mathematical model is available with known parameters it can be analyzed., for example by bode plots or nyquist plot , and controller can be designed for specific performances .such procedure is time consuming[18].

- Fuzzy logic controller has adaptive characteristics.

The adaptive characteristics can achieve robust performance to system with uncertainty parameters variation and load disturbances

7. Conclusion

Direct Torque Control is supposed to be one of the best controllers for driving any induction motor. Its main principles have been introduced and deeply explained. It is also demonstrated in this thesis that the method of DTC also allows the independent and decoupled control of motor torque and motor stator flux. A SIMULINK/MATALB® model has been fully developed. From the results it is apparent that DTC strategy is simpler to implement than the flux vector control method because voltage modulators and co-ordinate transformations are not required. Although, it introduces some disadvantages, being the torque ripple one of the worst.

References

- [1] Tejavathu Ramesh, Anup Kumar Pandl, Member IEEE, Y Suresh & Suresh. Mikkili@ "Direct Flux and Torque Control of Induction Motor Drive for Speed Regulator using PI and Fuzzy Logic Controllers" IEEE-International Conference On Advances In Engineering, Science And Management (ICAESM -2012) March 30, 31, 2012
- [2] Novotny, D. W. and Lipo, T. A. "Vector Control and Dynamics of AC Drives." Oxford University Press Inc, New York, 1996.
- [3] Vas, P. " Sensor less Vector and Direct Torque Control". Oxford University Press 1998.
- [4] Bose, B. K.; "Power Electronics and AC Drives". Prentice-Hall. 1986.
- [5] Mohan, Undeland, Robbins. "Power Electronics". Wiley. Second edition. 1989.
- [6] Ludtke, I.; Jayne M.G. "A comparative study of high performance speed control strategies for voltage sourced PWM inverter fed induction motor drives", Seventh International Conference on electrical Machines and Drives, 11-13 September 1995, University of Durham, UK.
- [7] Tamai, S., Sugimoto, H. and Yano, M. "Speed sensorless vector control of induction motor with model reference adaptive system." IEEE Industrial Applications Society Annual Meeting, Atlanta, pp.189-195, 1987.
- [8] Schauder, C. "Adaptive speed identification for vector control of induction motors without rotational transducers." IEEE Transactions on Industrial Applications, vol.28, pp. 1054-1061, 1992.
- [9] Doki, S., Sangwongwanich, S. and Okuma, S. "Implementation of speed sensorless field oriented



vector control using adaptive sliding observer." IEEE-IECON, San Diego, pp. 453-458, 1992.

[10] Kawamura, A. and Hoft, R. "An analysis of induction motor for field oriented or vector control." IEEE Power Electronics Specialists Conference, Albuquerque, New Mexico, pp. 91-100, 1983.

[11] Kubota, H. and Matsuse, K. "Speed sensorless field oriented control of induction machines." IEEE IECON, Bologna, Italy, pp. 1611-1615, 1994.

[12] Mir, S. and Elbuluk, M. "Precision torque control in inverter fed induction machines using fuzzy logic". Conf. Rec. IEEE-PESC Annual Meeting, Atlanta, pp. 396-401, 1995.

[13] Depenbrock, M. "Direct self control (DSC) of inverter– fed induction machine." IEEE Transactions on Power Electronics, vol. 3, no. 4, pp. 420- 429, 1988.

[14] Mir, S. and Elbuluk, M. "Precision torque control in inverter fed induction machines using fuzzy logic." Conf. Rec. IEEE-PESC Annual Meeting, Atlanta, pp. 396-401, 1995.

[15] Thomas, G., Halbetler, H. and Deepakraj, M. D. "Control strategies for direct torque control using discrete pulse modulation." IEEE Transactions on Industry Applications, vol. 27, pp. 893-901, 1991.

[16] Takahashi, I and Ohimori, Y. "High-Performance Direct Torque Control of an Induction Motor", IEEE Trans. Industry Applications, Vol. 25, pages 257-264, March 1989.

[17] Perelmuter, V. "Three level inverters with direct torque control." IEEE Proc. on Industry Applications, pp. 1368-1373, 2000.