



## Robot Controlling using Android Mobile Application Based on IoT

**Archana Pillani**

Department of Computer Science & Engineering,  
Siddhartha Institute of Engineering and Technology,  
Vinobha Nagar, Ibrahimpatnam, Hyderabad,  
Telangana 501506, India.

**B Mahender**

Department of Computer Science & Engineering,  
Siddhartha Institute of Engineering and Technology,  
Vinobha Nagar, Ibrahimpatnam, Hyderabad,  
Telangana 501506, India.

### ABSTRACT

*Now a day's technology becomes ever more invasive, the design challenges in home automation are increasingly apparent. Seamless controlling home, monitoring and programming by the end user have yet to enter the mainstream. This could be legitimate to the challenge of developing a fully independent and extensible home system that can support devices and technologies of differing functionalities and protocols. This paper describes how to control and monitor home appliances using android application over internet.*

*There are number of commercial home automation systems available in market. However, these are designed for limited use. Therefore, home appliances can individually be controlled both from within the home and remotely. This is very helpful to physically challenged people. The practical goal of this paper has been to create a virtual, but practically usable, android home automation system. The android mobile is used to send the commands to the Arduino to control all the home appliances. The main feature of this system is to control the voltage levels of home appliance in home like speed of fan based on temperature, intensity of light based on light intensity etc. and another feature is we may get the status of our home appliances from our android mobile phone.*

*In this system we use different sensors like temperature, rain sensor and LDR for different applications.*

**Key Words:** *Arduino, IoT, Android, Wi-Fi, Home Automation*

### INTRODUCTION

Automation is the most frequently spelled term in the field of electronics. The hunger for automation brought many revolutions in the existing technologies [1]. These had greater importance than any other technologies due to its user-friendly nature [7]. These can be used as a replacement of the existing switches in home which may produce sparks and also results in fire accidents in few situations [2]. Due to the advancement of wireless technology, there are several different technologies were introduced such as RFID, ZIGBEE, Bluetooth, GSM and Wi-Fi[8]. Each technology has their own unique specifications and applications. Considering the advantages of Wi-Fi an advanced automation system was developed to control the appliances in the house. In this paper we described about controlling all the home appliances using android application. All the appliances were controlled by Arduino Mega and Wi-Fi Module. In this we are using Wi-Fi Module to receive the commands from smart phone and processed by Arduino. In this design android application has developed by using Android SDK[13]. This proposed system can monitor and control all the home appliances.

### LITERATURE REVIEW

Many Authors designed home automation systems by using different technologies. By using GSM based home automation System we need to send message/make a call to control home appliances[14]. It has more time delay and complex system. By using Bluetooth home

**Cite this article as:** Archana Pillani, B Mahender, "Robot Controlling using Android Mobile Application Based on IoT", International Journal of Research in Advanced Computer Science Engineering, Volume 4 Issue 8, 2019, Page 1-7.

automation system also we can control all the home appliances. But the main disadvantage is Range[9,12]. Some authors designed home automation using Wi-Fi. But in those designs they implemented only ON/OFF functionalities. In our design we implemented ON/OFF functionality along with the voltage variations and all the home appliances are controlled by using android application.

**DESIGN AND IMPLEMENTATION**

The below figure 1 shows Proposed Home automation System using Android Application[3]. In this System we are using Arduino Mega, Rain Sensor, Temperature Sensor, LDR, Wi-Fi module, Relays, LCD display, Buzzer, Servo Motor, L293D motor Driver IC, MAX 232 and bulb.

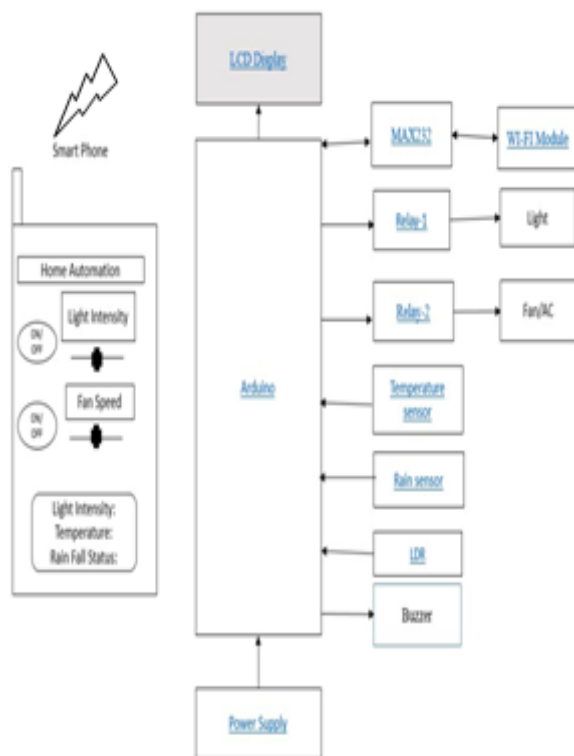

**Fig 1: Proposed Home automation System**

**LDR:** A light dependent resistor works on the principle of photo conductivity. When light fall on the LDR, the resistance decrease. Resistance is inversely proportional to the light.

**LM35:** The LM35 temperature sensor is used to detect the temperature levels in our home. The advantage of LM35 sensor is its low cost and highest sensitivity between +2ℱ C and +250ℱ C and a low power consumption at only +5v DC.

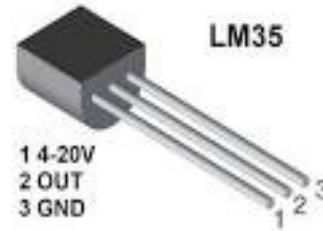

**Fig 2:LM35 Sensor**

**Rain Sensor:**

The Rain sensor is a simple tool to detect rain. This sensor can be used in measuring rainfall and it works as a switch when raindrops fall on the sensor board. This sensor consists of two parts: the controller and the rain board. This sensor is one of the members of the analog sensor family. Some properties of this type of sensor include the following: it operates on 5 volts; it includes two types of output: digital and analog; it is easy to install and use ; it has anti-oxidation properties; it is of high quality and is constructed with double sided material. The below Figure 3 shows a rain sensor module.

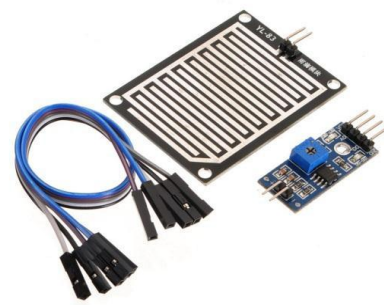
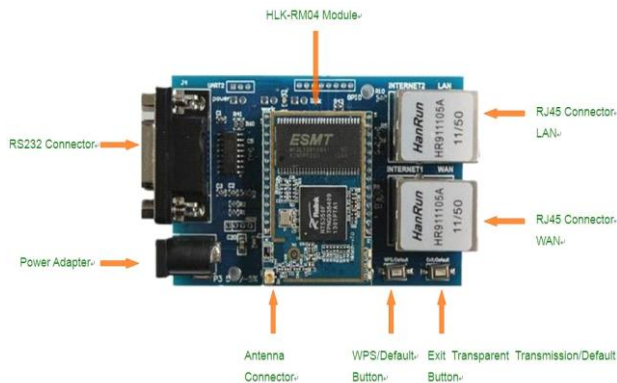

**Fig 3: Rain Sensor**

**Wi-Fi:**

In this design we used HLK-RM04 Wi-Fi module. It is developed by developed by Shenzhen Hi-Link Electronic Technology co., Ltd. By using HLK-RM04 module, the

habitual serial devices do not need to change any configuration. In this data can be transmitted through the Internet network. It gives a quick solution for the user's serial devices to transfer data via Ethernet or WiFi. The below figure 4 shows HLK-RM04 module.

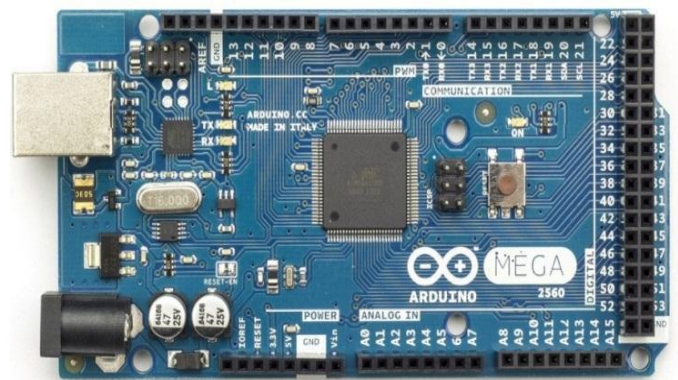

**Fig 4: HLK-RM04 Wi-Fi Module**

**WORKING:** The Arduino board is interfaced with the temperature sensor, LDR and rain sensor in order to control the fan speed, light intensity and to check the presence of rainfall. We can vary the speed of fan depending on the temperature at our home. Temperature is measured by using LM35 sensor. Similarly the intensity of light is varied depending on the necessity by using LDR. We can detect the presence of rainfall using Rain Sensor and status is displayed in the LCD display and android mobile. The status of light and fan are also displayed on the LCD display. The Wi-Fi module and the Arduino board are connected through MAX232. The light and fans are connected to Arduino board through relay which acts as switch. All these appliances are controlled using an Android application that is installed in our Android mobiles[11].

At first the application is connected with Wi-Fi module's IP address and then the characters are sending to the Arduino board through Wi-Fi module. Respective characters are assigned to the corresponding appliances in the code so that we can change the intensity of the light, speed of fan and check the status of rainfall by sending those codes through the application. ARDUINO Arduino is an open-source electronics prototyping

platform based on flexible, simple to use hardware and software[13]. It's proposed for artists, designers, hobbyists, and anyone interested in creating interactive objects or environments. In simple terms, the Arduino is a small computer system that can be programmed with instructions to interact with different forms of input and output. The current Arduino board model, the Mega, is small in size compared to the average human hand. It has many analog and digital IO pins. It operates with 5v power supply, which is connected from either USB port or External power supply. It can function between 5V – 20V. It has ATmega1280 micro controller. This microcontroller has many features. It has 128KB of flash memory, 4 KB of which are used for the Boot loader, 8 KB SRAM and 4 KB EEPROM.



**Fig 5: Arduino Mega Shield**

Arduino has e 54 digital IO pins. To select the input or output pin, we use the pinMode(), digitalWrite(), and digitalRead() functions. All this pins works at a maximum current of 40mA. These digital pins have some special functions. They are Serial 0: pin 0(RX), pin 1(TX), Serial 1: pin 19(RX), pin 18(TX), Serial 2: pin 17(RX), pin 16(TX), Serial 3: pin 15(RX), pin 14(TX). The TX is used to transmit the data and the RX is used to receive the data. The other special function pins are the SPI pins, SPI: MISO pin 50, MOSI pin 51, SCK pin 52, SS pin 53. It also has 16 analog input pins provides 10 bits of resolution (1024 different values) and uses the analogRead() function. In this we have 10 bit SAR ADC to convert analog data into digital form.



The Arduino Mega has many advantages. The below table 1 shows the comparison between Arduino Mega and Different Arduino boards. The Microcontroller ATmega1280 has four hardware UARTs for TTL (5V) serial communication. Also, the ATmega1280 has I2C pins and SPI pin communication.

**TABLE 1: COMPARISON BETWEEN ARDUINO MODULES**

| Arduino Type      | Mega2560    | UNO        | Nano       | Galileo   |
|-------------------|-------------|------------|------------|-----------|
| Digital I/O Pins  | 54 pins     | 14 pins    | 14 pins    | 14 pins   |
| Analog Input Pins | 16 pins     | 6 pins     | 8 pins     | 6 pins    |
| Processor         | ATmega 1280 | ATmega 328 | ATmega 168 | Intel     |
| Memory Size       | 128 KB      | 32 KB      | 32 KB      | 8Mbyte    |
| Clock Speed       | 16 MHz      | 16 MHz     | 16 MHz     | 400 MHz   |
| Cost              | Normal      | Cheap      | So Cheap   | Expensive |

### ANDROID:

Android is a software stack for mobile devices that include an operating system, middleware and key applications. Now days we have many tools to develop android applications. We can develop android applications using Android SDK, MIT App Inventor, Intel SDK and etc. According to user convenient we can use one of the tools. In this system we developed android

application using android SDK. The Android SDK provides the tools and APIs necessary to begin developing applications on the Android platform using Java. By providing an open development framework, Android offers developers the capability to build very rich and new applications. Developers have full access to the same framework APIs used by the core applications. Android includes a set of C/C++ libraries used by various components of the Android system. They include System Media library, C library, Surface Manager, SGL, LibWebCore, SQLite, Free Type and 3D libraries. The Android SDK compiles the code along with any data and resource files into an Android package, an archive file with an .apk file extension [12]. All the code in a single .apk file is considered to be one application and Home Automation using android System is the file that Android powered devices use to install the application. Once installed on a device, each Android application lives in its own security sandbox.

Some important application fundamentals are:

- The Android operating system is a multi-user Linux system where each application is a different user.
- By default, the system assigns each application a unique user ID. The system sets permission for all the files in an application so that only the user ID assigned to that application can access them.
- Each process has its own virtual machine, so an application's code runs in isolation from other applications.
- Every application runs its own Linux process.

### RESULTS & DISCUSSIONS

In this proposed system the main objective is to control home appliances using android mobile through Wi-Fi. This system has high security. To control home appliances first we need to login into android application by entering user name and password. User name and passwords are user defined. The below figure 6 shows the Login page of home automation using android application.

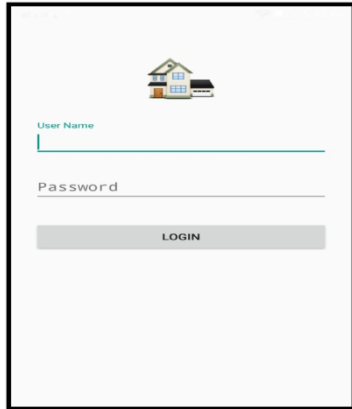

**Fig 6: Home automation Login page**

After logged into android application we need to establish network connection using IP address. It is shown in fig 6.



**Fig 7: Wi-Fi Connection window**

After establishing connection we can control all the home appliances using another window shown in fig 8. Here we are controlling two devices light and fan. As per user requirement we can connect many numbers of devices like TV, Refrigerator etc.



**Fig 8: Appliances Controlling Window**

In this system we will get light intensity levels through LDR. The below figure 9 shows the measured values of LDR, LM35 and Rain sensor in LCD.



**Fig 9: Sensor Output Values**

**Light Intensity Variations:**

The below figure 10 shows the output of bulb at low intensity level. Here we may decrease the light intensity at day time or during sleep time. Intensity levels of light will be displayed on LCD based on LDR Values.

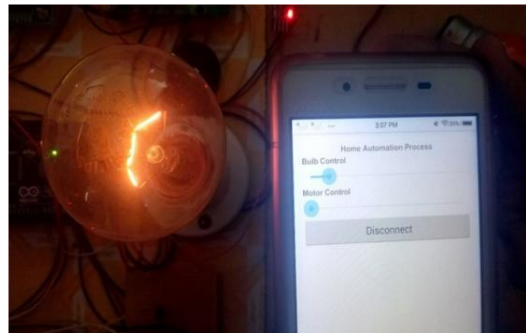

**Fig 10: Output at Low Light Intensity Level**

The below figure 11 shows the output of bulb at high intensity level. At night time light intensity levels in environment will be low. Based on the light intensity levels we may increase the brightness of light. Intensity levels in home will be displayed on LCD based on LDR Values.

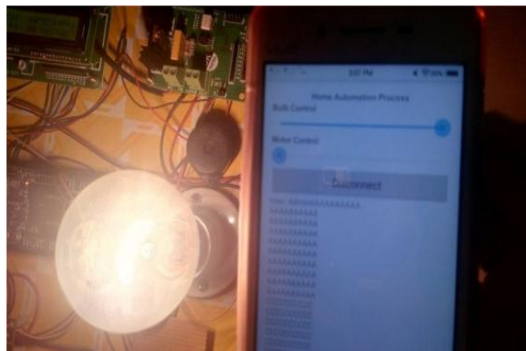

**Fig 11: Output at High Light Intensity Level**

**Fan Speed Controlling:**

The below figure 12 shows the controlling of fan speed based on room temperature. Whenever the temperature decreases we need to decrease the speed of fan. In this system we used LM35 to measure temperature in our home.



**Fig 12: Running Fan at low speed**

The below figure shows the controlling of fan speed based on room temperature. Whenever the temperature increases we need to increase the speed of fan. In this system we used LM35 to measure temperature at our home.



**Fig 13: Running Fan at high speed**

The below figure 14 shows the output of rain sensor based on presence of rain fall. When the rain fall occurs buzzer gives an indication regarding the status of rain fall.

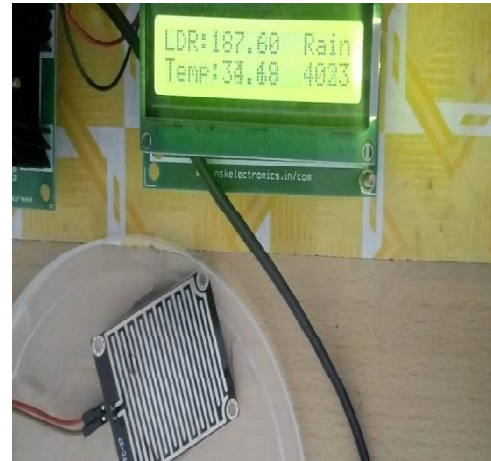

**Fig 14: Rain Sensor Values Displaying in LCD**

The below figure 15 shows the Home automation Kit picture. It has Arduino mega, LDR, LM35, LCD, relay, motor, motor driver circuit and Wi-Fi module. All the home appliances are connected to relay board. In this all the devices are controlled by using android mobile application. In this we can control the light intensity and fan speed based on LDR and LM35 sensor values respectively.

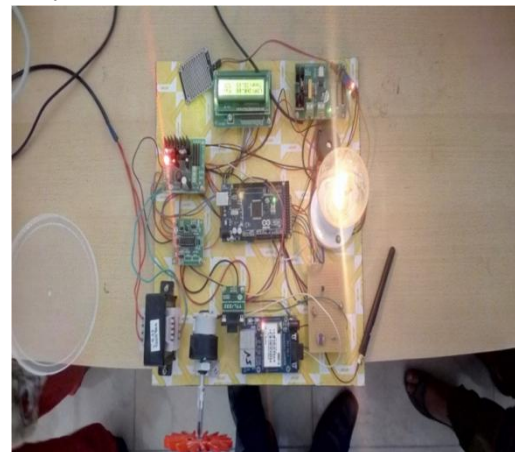

**Fig 15: Results of Home Automation Using Android**

**CONCLUSION**

The aim of this work is the development of wireless control of a robot using Android application. This project proposes a low cost, secure, universally accessible, auto-configurable, remotely controlled solution. The approach discussed in the paper is original and has achieved the mark to control home appliances remotely using the Wi-





Fi technology to connect system parts, satisfying user needs and requirements. Wi-Fi technology capable solution has proved to be controlled remotely, provide home security and it is low cost as compared to the previous systems.

The system design and architecture were discussed, and prototype presents the basic level of home appliance control and remote monitoring has been implemented. Finally, the proposed system is better from the scalability and flexibility point of view than the commercially available home automation systems.

## FUTURE WORK

The current version of the Processing application helps in detecting the accident and helps to release the air bag and also sensing the disturbance as vibration from the 2 meters distance and gives the control using ultrasonic sensor and the buzzer gives the sound when there is any vibration. It can be applied to the Automatic Vehicle Monitoring, Device Control Robot Applications and Android based Vehicle Control Systems.

## REFERENCES

- [1] P. P. Ray, "A Survey on Internet of Things Architectures" in Journal of King Saud University-Computer and Information Sciences, Elsevier, vol. 2016.
- [2] P. P. Ray, "A Survey of IoT Cloud Platforms" in Future Computing and Informatics Journal, Elsevier, vol. 1, no. 1-2, pp. 35-46, 2016.
- [3] P. P. Ray, "Internet of Robotic Things: Concept Technologies and Challenges", IEEE Access, vol. 4, pp. 9489-9500, 2016.
- [4] J. Pollard, Robots and the Internet of Things will change your world but do you want that
- [5] P. Valerio, Amazon Robotics: IoT in the Warehouse, [online] Available:

<http://www.informationweek.com/strategic-cio/amazon-robotics-iot-in-the-warehouse/d/d-id/1322366>.

- [6] C. Turcu, C Turcu, V. Gaitan, "Merging the Internet of Things and Robotics" in Recent Researches in Circuits and Systems, pp. 499-504, 2012.
- [7] C. Crick, Graylin Jay, Sarah Osentosiki, Benjamin Pitzer, Odest Chadwicke Jenkins, "Rosbridge: ROS for non-ROS Users" in International Foundation for Robotics Research, pp. 1-12, 2011.
- [8] R. Toris, "Message Authentication Codes for Secure Remote Non-Native Client Connections to ROS enabled Robots", proceedings of IEEE International Conference on Technologies for Practical Robot Applications (TePRA), pp. 1-6, 2014.
- [9] P. P. Ray, "Internet of Things based Physical Activity Monitoring (PAMIoT): An Architectural Framework to Monitor Human Physical Activity", Proceeding of IEEE CALCON, pp. 32-34, 2014.
- [10] P. P. Ray, "Home Health Hub Internet of Things (H3IoT): An Architectural Framework for Monitoring Health of Elderly People", Proceeding of IEEE ICSEMR, 2014.
- [11] P. P. Ray, "Internet of Things for Sports (IoTSport): An architectural framework for sports and recreational activity", Proceeding of IEEE EESCO, pp. 79-83, 2015.
- [12] S. Sebastian, P. P. Ray, "Development of IoT Invasive Architecture for Complying with Health of Home", Proc. of International Conference on Computing and Communication Systems (I3CS), pp. 79-83, 2015.
- [13] S. Sebastian, P. P. Ray, "When Soccer Gets Connected to Internet", Proceeding of International Conference on Computing and Communication Systems (I3CS), pp. 84-88, 2015.